

SEDGEFIELD

APPROXIMATELY 1257 SF

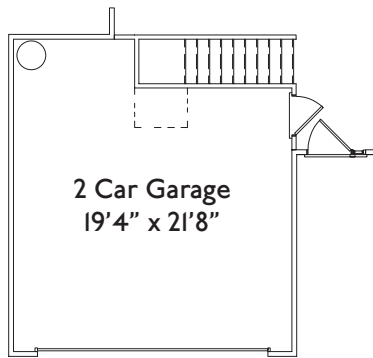

First Floor w/
Opt. Bonus Room

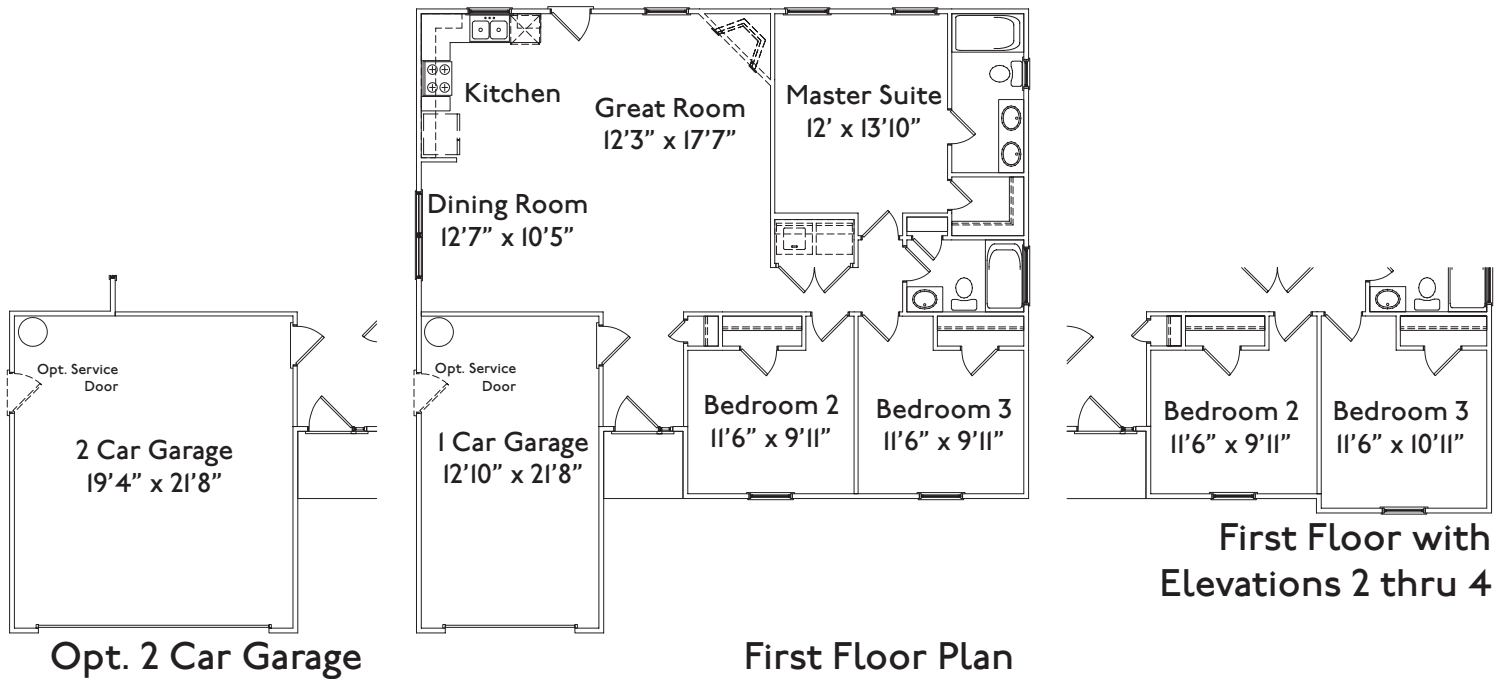
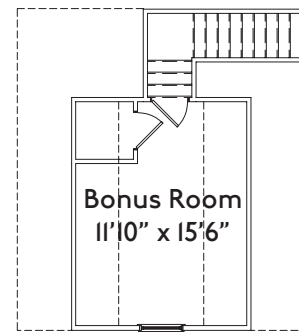

Opt. Bonus Room
(Requires 2 Car Garage)

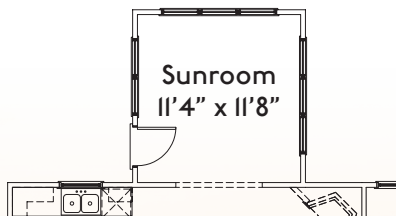

Opt. Sunroom

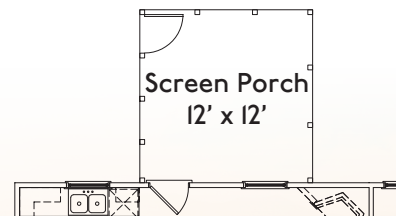

Opt. Screen Porch

Room Sizes and square footage are approximate. Standard features vary per community. Consult the Standard Features document for details. Because we are constantly improving our homes, we reserve the right to revise, change and/or substitute features, dimensions, architectural details and designs without notice. Any illustrations, including photographs, are for discussion purposes only and are not part of the legal contract. Pricing is subject to change without notice.

